



MONTICELLO
Charlottesville, Virginia, 1772,
Thomas Jefferson.



KUPPELGEBÄUDE

Dieses Modell enthält viele typische Elemente des Neoklassizismus, unter anderem ein auffälliges Kuppeldach.

Die Gesamtform folgt Thomas Jeffersons Entwurf für Monticello. Der Entwurf könnte als palladinisch bezeichnet werden, denn er ist streng symmetrisch und weist Säulen und Pedimente auf.

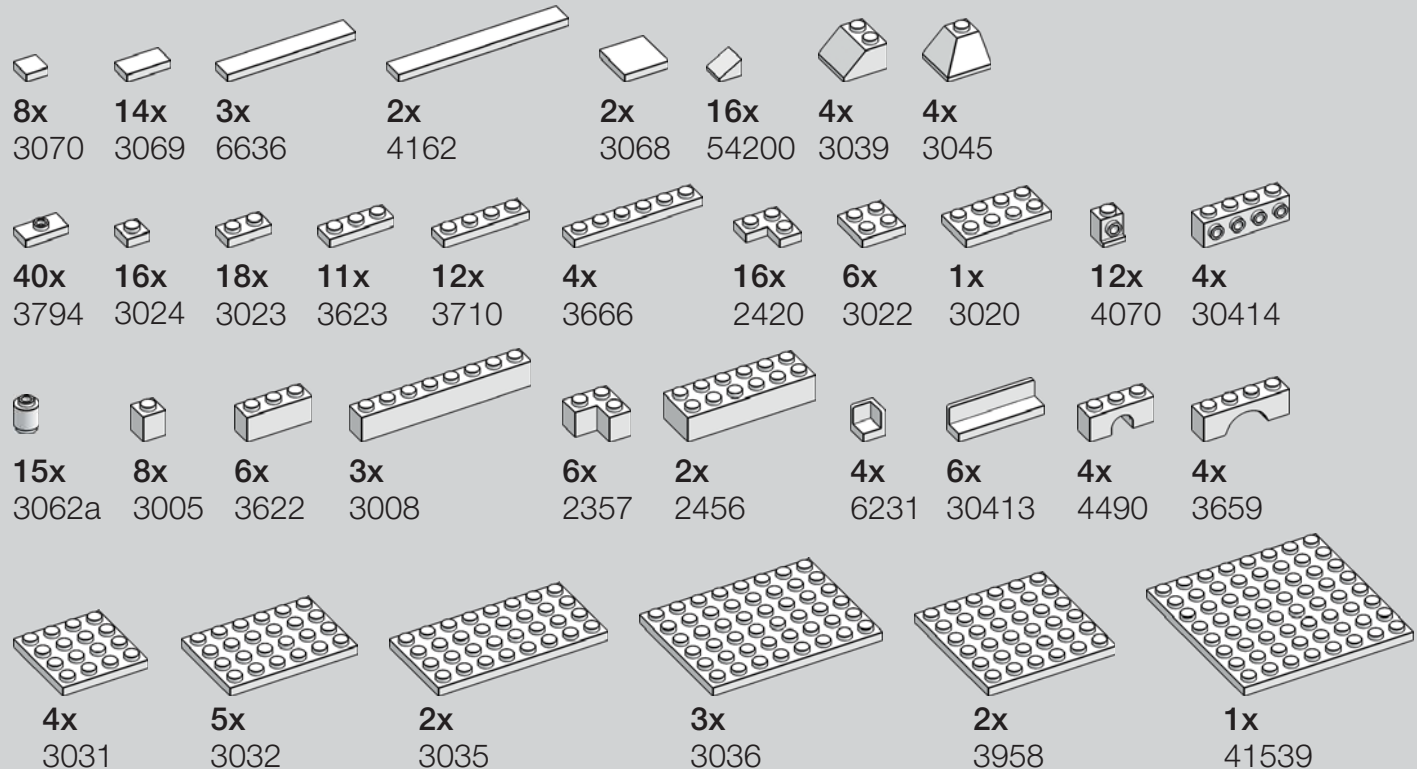
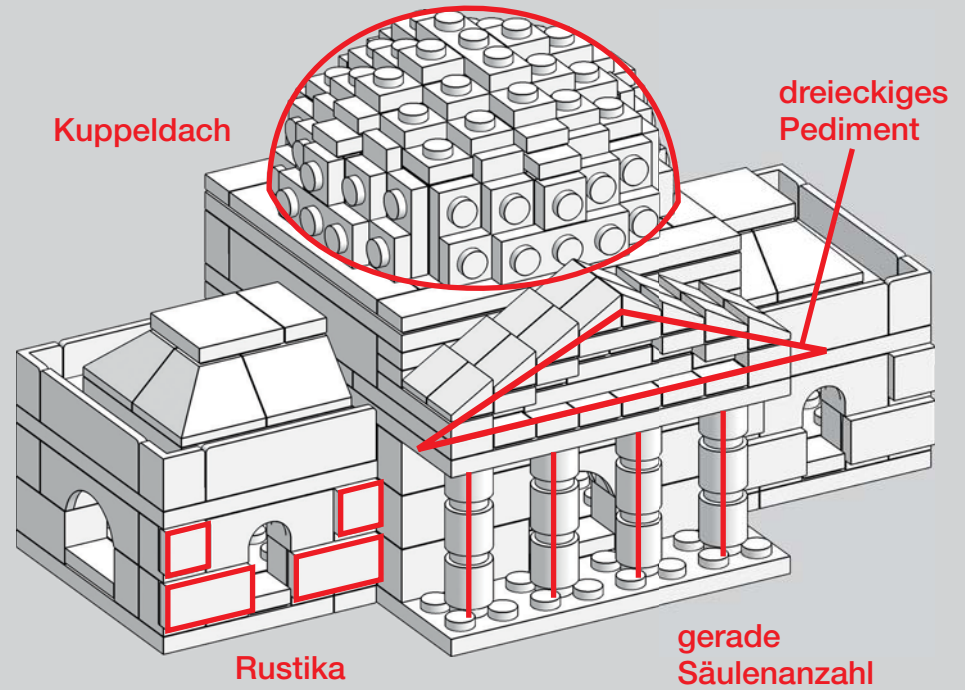

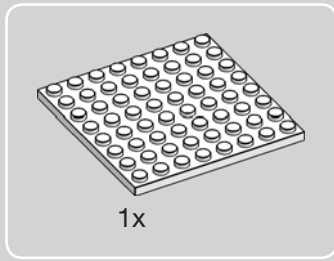

1

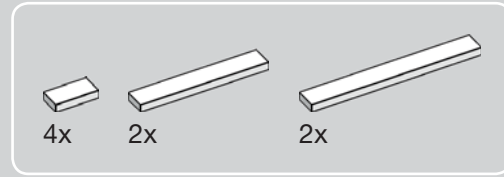
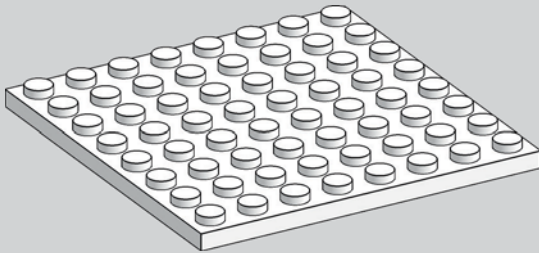

2

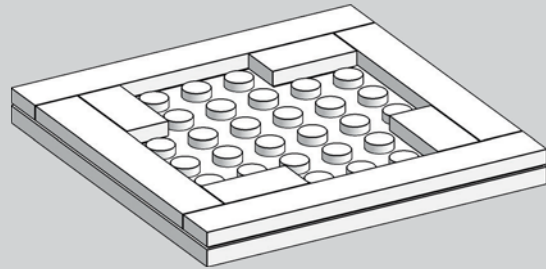

3

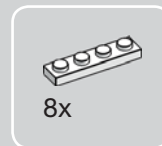
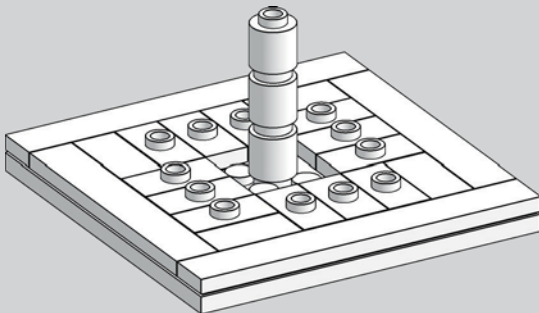

4

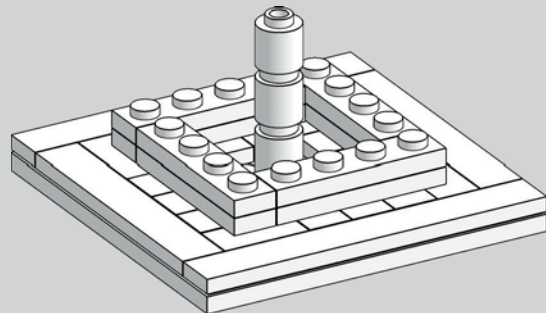

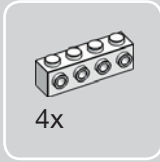

5

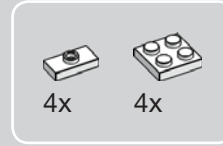
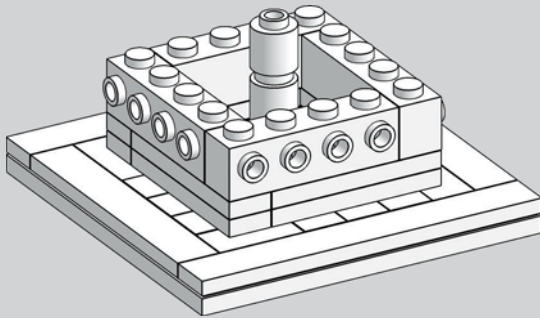

6

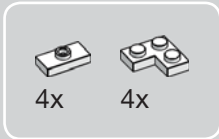
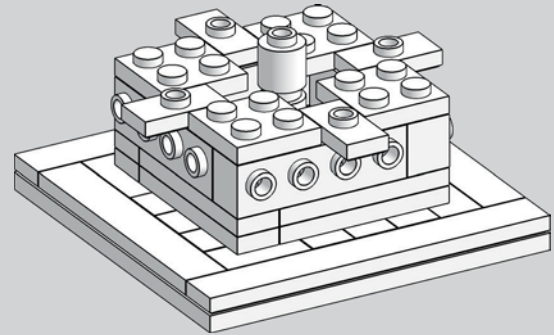

7

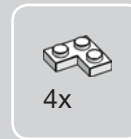
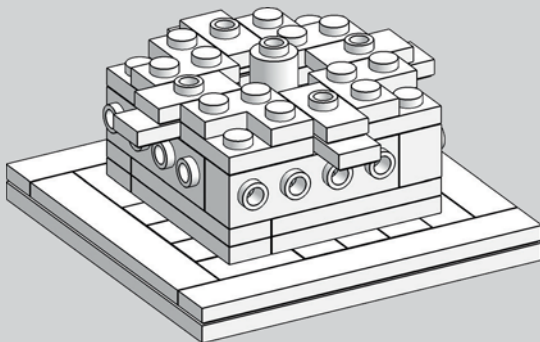

8

